

Field Hydrostatic Pressure Testing Of Polyethylene Pressure Pipelines

Field testing is performed on fully assembled pipelines for the purpose of determining pipeline acceptability. Following visual acceptance of joints and pipeline components, pressure pipelines in their entirety or in sections are subjected to hydrostatic pressure testing revealing the occurrence of joining/installation faults and confirming the structural integrity and fitness of the pipeline for its intended application. Destructive testing of randomly/regularly cut fusion joints may predate the field pressure testing.

Polyethylene pressure pipeline field testing procedures outlined below are based on recommendations of AS/NZS 2566.2:2002 and AS/NZS 2033:2008, and include:

- Basic pressure test (Visual).
- General pressure test (Technical) - Constant pressure (water loss) method.
- Pressure decay method.
- Modified pressure rebound method.

A hydrostatic test pressure of 1.25 times the maximum working pressure shall be applied to the pipeline section under test. The test pressure at any point shall be not less than the design pressure and not more than 1.25 times the rated pressure of the lowest rated pipeline component. At least two calibrated test gauges must be used to ensure this requirement.

Typical field pressure test equipment layout is shown below (source - AS/NZS 2566.2:2002, Figure M2).

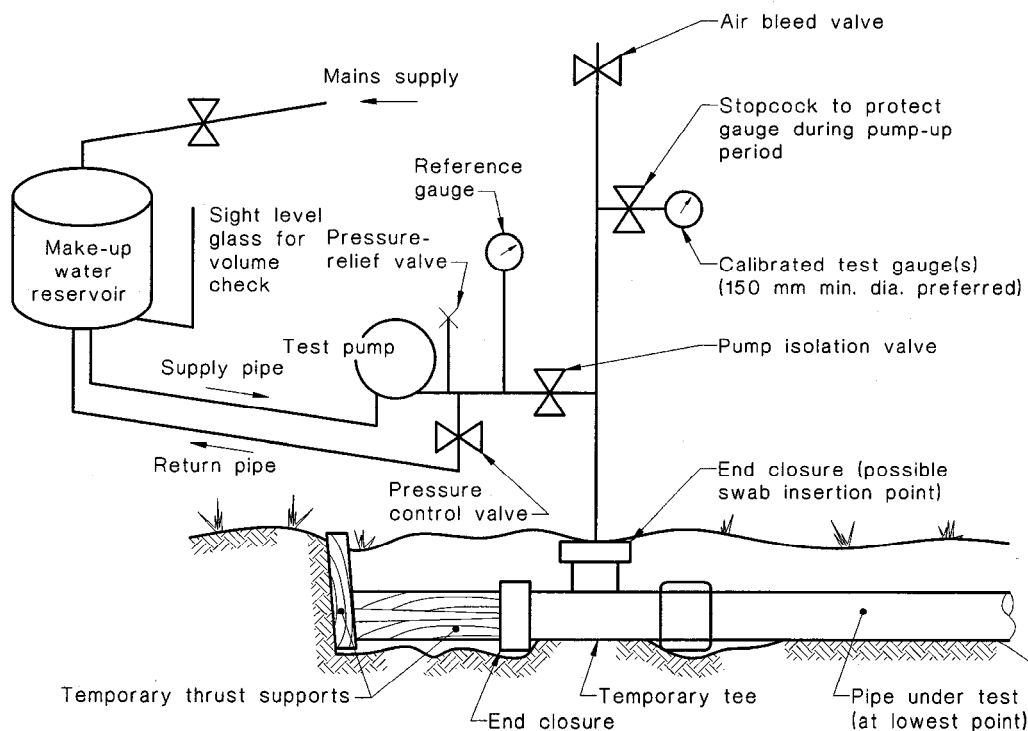

Information or advice contained in these guidelines or obtained from Waters & Farr otherwise is given in good faith. Waters & Farr make no warranty or representation regarding the information, opinions and recommendations contained in the guidelines. Users of the guidelines are advised to seek and rely upon their own professional advice and assessment of the matters contained in the guidelines. Waters & Farr excludes all liability to any user of the guidelines for consequential or indirect damages, or any other form of compensation or relief whatsoever for any acts or omissions of Waters & Farr, arising out of or in connection with the use of the guidelines irrespective of whether the same arises at law, inequity or otherwise.

Waters & Farr
 105 Neilson St, Onehunga
 PO Box 13329, Onehunga
 Auckland, New Zealand
 Phone +64 9 622 4036
 Fax +64 9 622 4037

Pre-test procedures include the following:

- All required temporary and permanent thrust blocks shall be in place and all concrete adequately cured.
- Temporary or permanent test section blanking arrangements (like blank flanges or caps, closed valves) shall be of adequate loading capacity and shall be strutted or anchored for the whole duration of the test unless they are already fully restrained or are end load resistant.
- Where practicable, all bolted joints shall be left exposed to allow for re-tensioning, and other joints shall be left exposed for visual leak detection.
- The test equipment shall be placed in position and checked for satisfactory operation.
- The pump shall be of adequate size to raise and maintain the test pressure.
- The pipeline pressurizing time shall not exceed 45 minutes (usually is planned to be 15 minutes). The pressurizing time affects the duration of the test.
- The pipeline (test section) shall be filled with water from the lowest point ensuring air is vented at the high point valves. The recommended rate of filling based on flow velocity of 0.05 m/s is calculated from the following equation:

$$Q_f \leq 12.5\pi D^2,$$

where Q_f - filling rate, in l/s,

D - pipe internal diameter, in m.

A firm foam swab may be used ahead of the fill water to assist air removal especially where the pipeline undulates. The swab is extracted at a high point wash-out.

- The test section shall be left to stabilize overnight, if possible, or for a minimum period of 3 h, to allow the temperature to stabilize and dissolved air to exit the system.

All necessary safety precautions must be observed including installation of safety barriers where required.

Basic pressure test (Visual) is performed by application of the test pressure and isolation of the pipeline by closing the high point air release valves.

Where the joints are accessible for inspection, the pump input valve is closed and the test section is visually inspected for leakage (for at least 15 minutes) at all joints including fusion joints, mechanical connections, service connections, valves, etc. **The test length is accepted** if there is no visible leakage and no failure of any pipeline component.

Where the joints are not accessible for inspection, maintain the test pressure by the addition of measured and recorded quantities of make-up water at regular intervals. **The test length is accepted** if the apparent loss of water is less than that calculated from the following equation:

$$Q \leq 0.14LDH,$$

where Q - allowable make-up water, l/h,

L - length of the test section, in km,

D - nominal diameter of the test length, in m,

H - average test head over length of the test section, in m.

Normally the test should last for a minimum of 2 h and be concluded within 5 h to 8 h. Where, after 12 h the make-up water still exceeds the allowable limit, testing should cease and the cause of loss investigated.

Following acceptance of the pipeline, high point air release valves shall be opened, the test water shall be **slowly** drained to an approved waterway and all connection points shall be reinstated.

Where a leak is detected, it shall be repaired, and the pipeline shall be re-tested.

General pressure test (Technical) - Constant pressure (water loss) method

Constant pressure test (water loss method) is regarded as independent of soil support and is sometimes referred to as a reference test.

The procedure of the constant pressure test is initiated as follows:

- Purge the air from pipeline.
- Apply the specified test pressure (STP) to the test section. Shut off main and allow pressure to settle for 12 h (pressure will drop significantly).
- As possible, inspect for leaks during this period. If a leak is detected, repair and re-start the test.
- Using water of the same temperature as that in the pipeline ($\pm 3^{\circ}\text{C}$) restore and maintain STP for 5 h.
- Measure and record water volume (V_1 , in l) required to maintain this pressure between 2 hours and 3 hours from start.
- Measure and record water volume (V_2 , in l) required to maintain this pressure between 4 hours and 5 hours from start.
- For optimum test protocol, the following tolerances are recommended (not mandatory):

water volume: $\pm 10D$ litres, where D - pipe nominal diameter, in m,

time: ± 1 min.,

pressure: ± 1 kPa.

- Calculate:

$$0.55V_1 + Q,$$

where Q - allowable make-up water, l/h, obtained from: $Q = 0.14LDH$,

L - length of the test section, in km,

D - pipe nominal diameter, in m,

H - average test head over length of the test section, in m.

- **The test section shall be acceptable** if: $V_2 \leq 0.55V_1 + Q$.

The test section shall not be acceptable if the above criterion is not satisfied.

The test section shall not be acceptable also if there is a failure of any pipe component or visible leakage.

After testing, pipelines shall be depressurised slowly. All air venting facilities shall be open when emptying pipelines. The test water shall be drained to an approved waterway and all connection points shall be reinstated.

The faults shall be detected and corrected, and the pipeline retested.

Pressure decay test

Due to creep response and stress relaxation of the material, the test pressure applied to a leak-free polyethylene pipeline will decay in a non-linear manner as shown on figure to the right

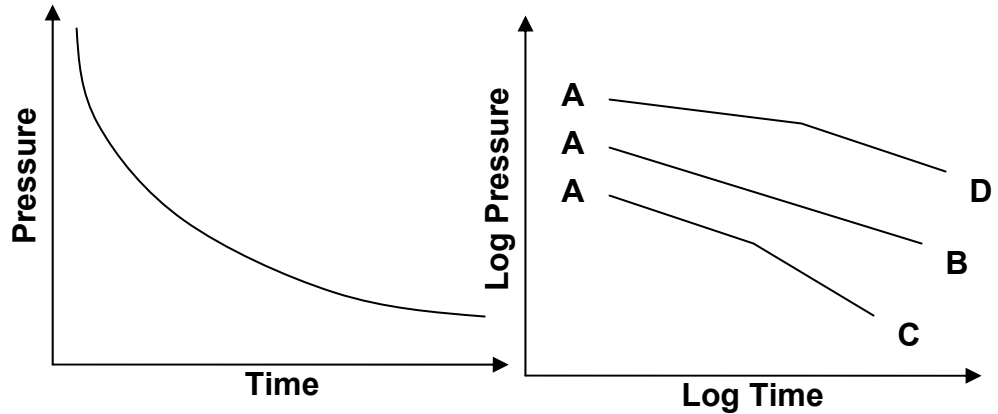

(source - AS/NZS 2566.2:2002, Figure 6.1). When expressed in logarithmical coordinates, the result is expected to be a straight line (like line A-B). A change to a steeper slope (line A-C) indicates leakage in the system; initial flatter slope (line A-D) indicates air entrapment at the start of the test.

The procedure of the pressure decay test is initiated as follows:

- Apply the specified test pressure (STP) by pumping water continuously at a constant rate and isolate the high point air release valves and the pump feed valve by closing them.
- Monitor and record the pressure rise and the time taken (loading time t_L) to reach the test pressure.

Apply the three-point analysis test procedure as follows:

- At the moment of valve closure, time $t = 0$.
- Take the first reading of pressure P_1 at t_1 , where $t_1 = 0 + t_L$ (see the diagram below; source - AS/NZS 2566.2:2002, Figure M4).
- Take a second reading of pressure P_2 at a t_2 (approximately $7 \times t_L$).
- Take a third reading of pressure P_3 at a t_3 (not less than $15 \times t_L$).

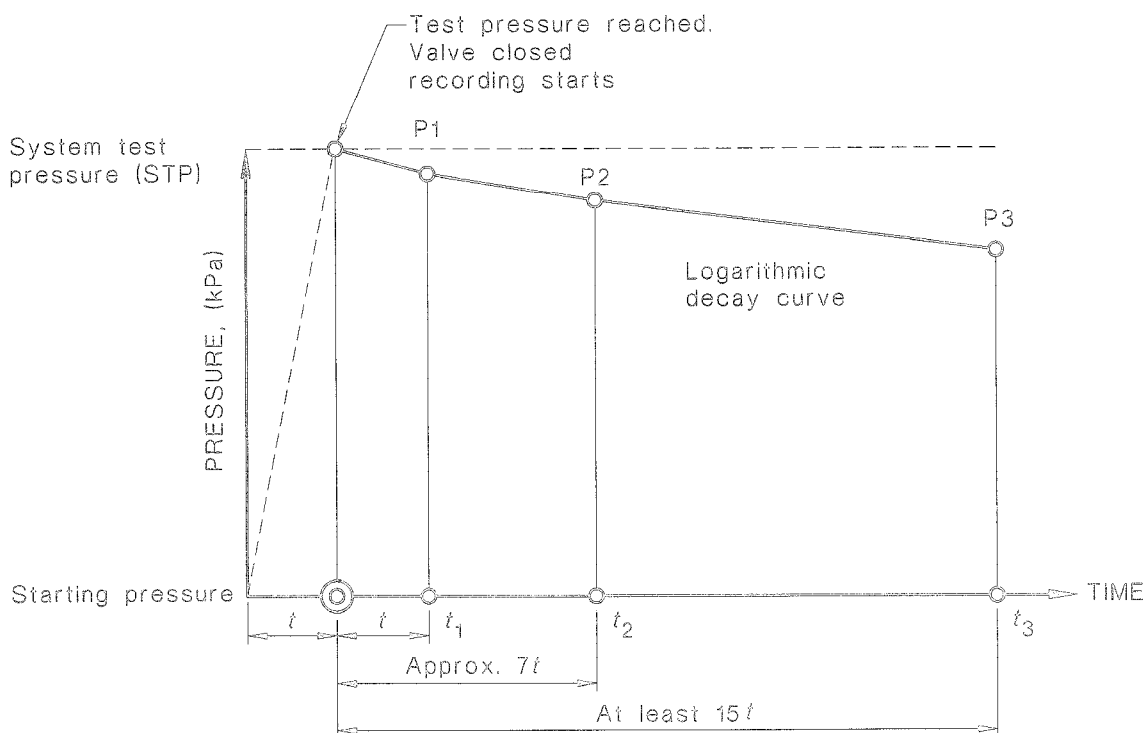

- To allow for the creep behaviour of PE pipeline whilst being pressurised, calculate the corrected values of t_1 , t_2 and t_3 as follows:

$$t_{1c} = t_1 + 0.4 \times t_L$$

$$t_{2c} = t_2 + 0.4 \times t_L$$

$$t_{3c} = t_3 + 0.4 \times t_L$$

- Calculate the slope of the pressure decay curve between t_1 at a t_2 (slope n_1) using:

$$n_1 = (\log P_1 - \log P_2) / (\log t_{2c} - \log t_{1c})$$

and between t_2 at a t_3 (slope n_2) using:

$$n_2 = (\log P_2 - \log P_3) / (\log t_{3c} - \log t_{2c})$$

- The test section shall be acceptable** (no leakage) if n_1 and a n_2 lie within the range 0.04 to 0.1, as follows:
 - 0.08 – 0.10 for unsupported pipes (e.g., slip lined or no backfill).
 - 0.05 – 0.08 for pipes in intermediate ground conditions.
 - 0.04 – 0.05 for pipes in compacted backfill.

Note, that some environmental factors leading to significant change of pipeline temperature during the procedure may contribute to small deviations from the above range.

The test section is also acceptable if the plotted line is not straight, but is within the above range for the second slope (the first slope was shallow – initial entrapment of a small amount of air; the first slope was slightly steeper – possibly due to a small steep drop of pressure prior to t_1) or, being within the above range for the first slope, becomes shallow for the second slope (possibly due to pipe reaching an obstruction for expansion).

The test section shall not be acceptable when the plotted line is not within the above range for both slopes or is steeper for the second slope. The following interpretations may provide guidance:

- $n < 0.04$: there is probably air in the system.
- $n > 0.10$: the system is probably leaking.
- $n \gg 0.15$: there is almost certainly a leak.

The test section shall not be acceptable also if there is a failure of any pipe component or visible leakage.

Problems with pipelines may be predicted earlier by comparing the actual pressure with the predicted pressure, which is calculated using the following equation:

$$P = P_L (2.5(t/t_L) + 1)^{-n}$$

where P - predicted pressure at time t ,

P_L - test pressure at start of test,

t_L - loading time,

n - slope of the pressure decay curve (may be taken as 0.10 for pipes without constraint, or as 0.05 for pipes with compacted backfill).

After testing, pipelines shall be depressurised slowly. All air venting facilities shall be open when emptying pipelines. The test water shall be drained to an approved waterway and all connection points shall be reinstated.

The faults shall be detected and corrected, and the pipeline retested.

The minimum time between repeat tests shall be 5 times the total test time.

Pressure rebound method

Modified pressure rebound method is a quicker way to confirm absence of leaks and is also regarded as independent of soil support. It is applicable for PE pressure pipelines up to and including DN 315. The test procedure includes three phases.

Preliminary phase

- Depressurized pipeline (pressure is just above atmospheric at the highest point of the test section) is allowed to relax for 60 min. (no air shall enter the system).
- Pressurize the test section smoothly to the specified test pressure (**STP**) in less than 10 min. Hold the pressure at STP for 30 min., pumping as needed (do not exceed STP). Inspect for leaks during this period.
- Shut off pressure, allow pressure to decay for 60 min.
- Measure the pressure remaining for 60 min. (P_{60}).
- If $P_{60} \leq 70\%$ of **STP**, the test has failed. Following rectification of the cause, the above steps shall be repeated. If $P_{60} > 70\%$ of **STP**, proceed to the second phase.

Air volume assessment

- Quickly (<5 min.) reduce pressure by ΔP (10%-15% of STP) – measure accurately.
- Accurately measure water volume bled out (ΔV).
- Calculate $\Delta V_{max\ allowable}$ as follows:

$$\Delta V_{max\ allowable} = 1.2 \times V \times \Delta P (1/E_W + D/E_R),$$

where 1.2 - air allowance,

V - pipe volume, in l,

ΔP - measured pressure drop, in kPa,

D - internal pipe diameter, in m,

E_R - pipe material modulus, in kPa (see table below; source - AS/NZS 2566.2:2002, Tables M1),

E_W - bulk modulus of water, in kPa (see table below; source - AS/NZS 2566.2:2002, Tables M1).

Pipe material modulus E_R for PE 80B and PE 100

Temp., °C	PE 80B – E Modulus (kPa×10 ³)			PE 100 – E Modulus (kPa×10 ³)		
	1 h	2 h	3 h	1 h	2 h	3 h
5	740	700	680	990	930	900
10	670	630	610	900	850	820
15	600	570	550	820	780	750
20	550	520	510	750	710	680
25	510	490	470	690	650	630
30	470	450	430	640	610	600

Bulk modulus E_W - water

Temp., °C	Bulk Modulus (kPa×10 ³)
5	2080
10	2110
15	2140
20	2170
25	2210
30	2230

- If $\Delta V > \Delta V_{max\ allowable}$, the test has failed. Following rectification of the cause, the preliminary phase and the above steps shall be repeated. If $\Delta V < \Delta V_{max\ allowable}$, proceed to the main phase.

Main test phase

- Observe and record the pressure rise for 30 min.
- **The test section shall be acceptable** if the pressure rises or remains static within the 30 min. period.

- If in doubt, increase the monitoring period to 90 min. **The test section shall be acceptable** if the pressure drop does not exceed 20 kPa over the 90 min. period.
The test section shall not be acceptable if the pressure drops by more than 20 kPa during the 90 min. period.
The test section shall not be acceptable also if there is a failure of any pipe component or visible leakage.

Typical successful extended period modified rebound test for a PE pipeline is shown below (source - AS/NZS 2566.2:2002, Figure M5).

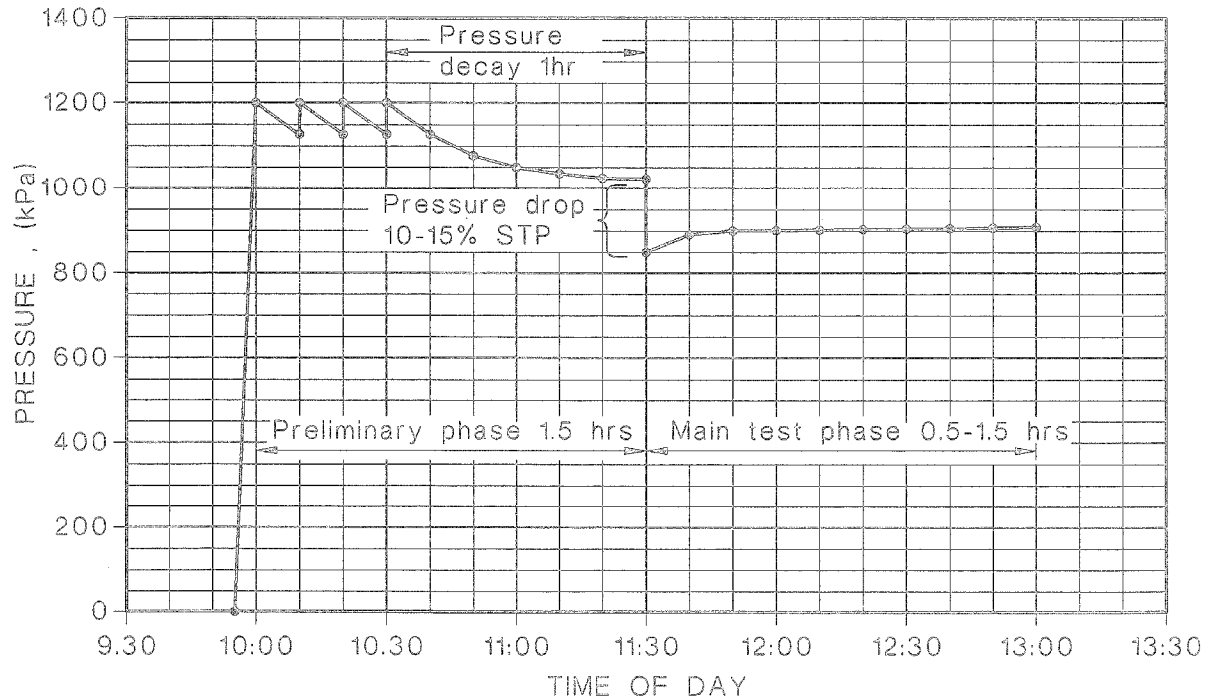

After testing, pipelines shall be depressurised slowly. All air venting facilities shall be open when emptying pipelines. The test water shall be drained to an approved waterway and all connection points shall be reinstated.

The faults shall be detected and corrected, and the whole test shall be repeated.

Test report usually includes full details of the pipeline tested, test method, test station location, dated test data and results, water and ambient temperatures, details of faults, dated retest data and results.

For more detailed description of procedures for field testing of PE pipelines and as a reference document, refer to AS/NZS 2033 and AS/NZS 2566.2.